

Cushyfloat™

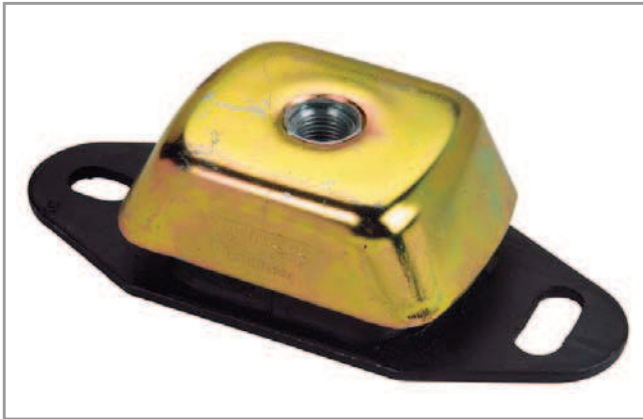

Metalastik® type Cushyfloat™

The Cushyfloat™ mounting is an ideal general purpose unit designed to provide effective isolation of vibration and noise arising from many types of static and mobile equipment including:

- ▼ Pumps
- ▼ Compressors
- ▼ Generator sets
- ▼ Marine, industrial and vehicle engines

Features

Originally designed for use with marine engines, this compact low profile mounting is easy to install. It combines 3 way control of the suspended equipment with relatively large static deflections where the rubber is loaded in shear and compression.

The design incorporates bump and rebound control features which limit excessive movements under shock loading. Top metal cover gives protection against oil contamination.

Protective finish resists corrosion attack. Propeller thrust on marine applications is accommodated. There are four sizes in the standard range which with varying degrees of rubber hardness cater for point loads from 32 kg to 3000 kg. Natural frequencies as low as 8 Hz are possible.

* When used in marine engine applications with thrust forces involved, the maximum load capacity is substantially reduced, see table below!

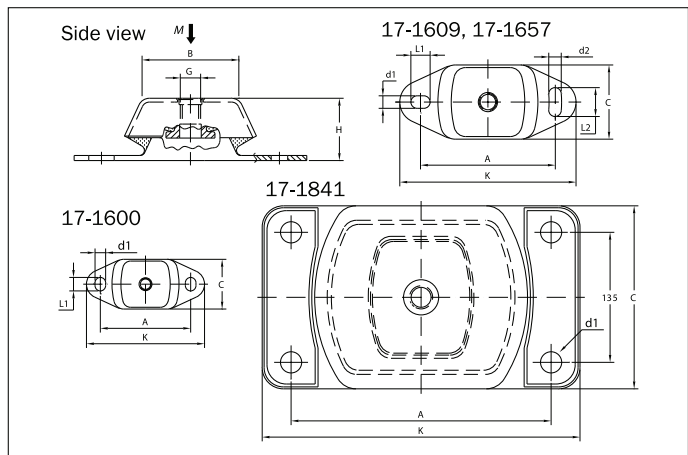

Drawing no.	Part no.	Dimensions in mm										M-max (Kg)	*M-max (Kg)	Max longitudinal force F(N)	Weight (Kg)
		B	C	A	K	H	d1	L1	d2	L2	G				
17-1600-1	10-00535	60	60	100	120	38	11	14	--	--	M12	50	35	370	0,3
17-1600-1	10-00536	60	60	100	120	38	11	14	--	--	M12	65	55	560	0,3
17-1600-1	10-00537	60	60	100	120	38	11	14	--	--	M12	100	80	830	0,3
17-1609-1	10-00545	75	75	140	183	50	13	20	13	30	M16	150	95	1000	0,9
17-1609-1	10-00546	75	75	140	183	50	13	20	13	30	M16	210	140	1500	0,9
17-1609-1	10-00547	75	75	140	183	50	13	20	13	30	M16	300	210	2300	0,9
17-1609-1	10-00548	75	75	140	183	50	13	20	13	30	M16	450	315	3300	0,9
17-1657-1	10-00557	80	112	182	230	70	18	26	18	34	M20	350	250	2800	2,4
17-1657-1	10-00558	80	112	182	230	70	18	26	18	34	M20	520	370	4200	2,4
17-1657-1	10-00559	80	112	182	230	70	18	26	18	34	M20	800	560	6400	2,4
17-1657-1	10-00560	80	112	182	230	70	18	26	18	34	M20	1000	700	11800	2,4
17-1841-2	10-00605	221	190	270	330	110	Ø22	--	--	--	M24	950	630	5300	9,6
17-1841-2	10-00606	221	190	270	330	110	Ø22	--	--	--	M24	1400	945	7100	9,6
17-1841-2	10-00607	221	190	270	330	110	Ø22	--	--	--	M24	2200	1575	12500	9,6
17-1841-2	10-00608	221	190	270	330	110	Ø22	--	--	--	M24	3000	2100	18000	9,6

Note: The natural frequencies and degrees of isolation are based on dynamic characteristics of the mountings.

Load per mounting (kg)

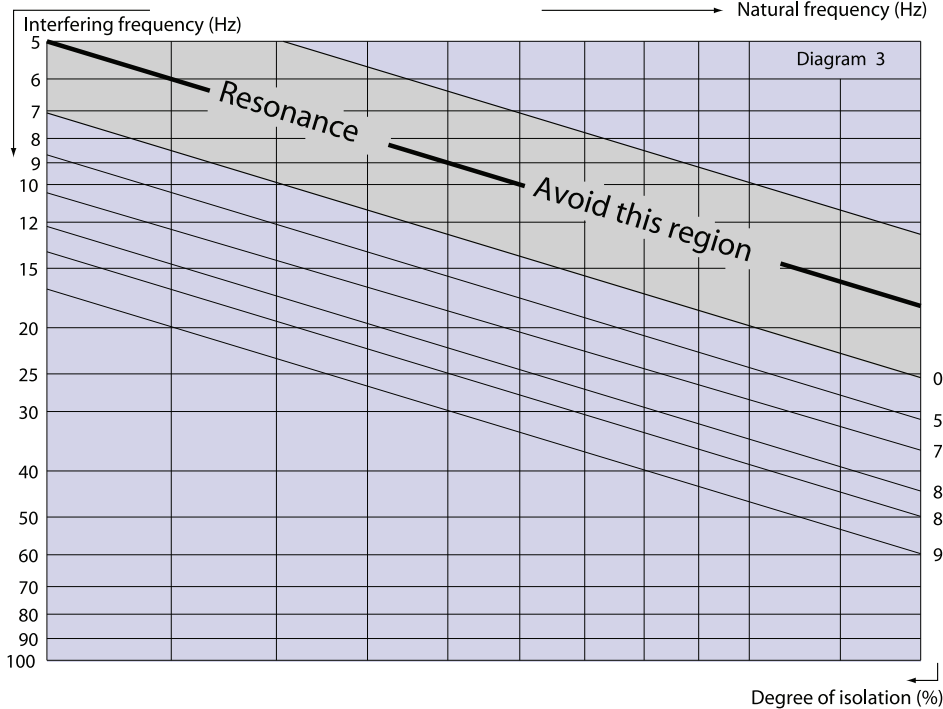
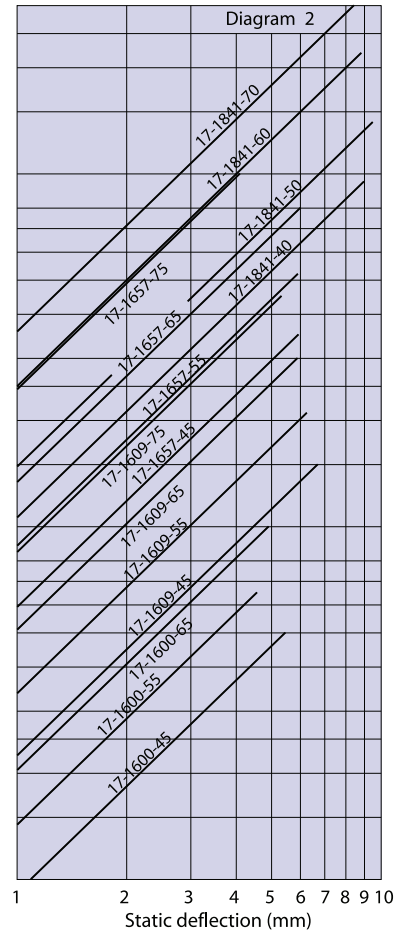
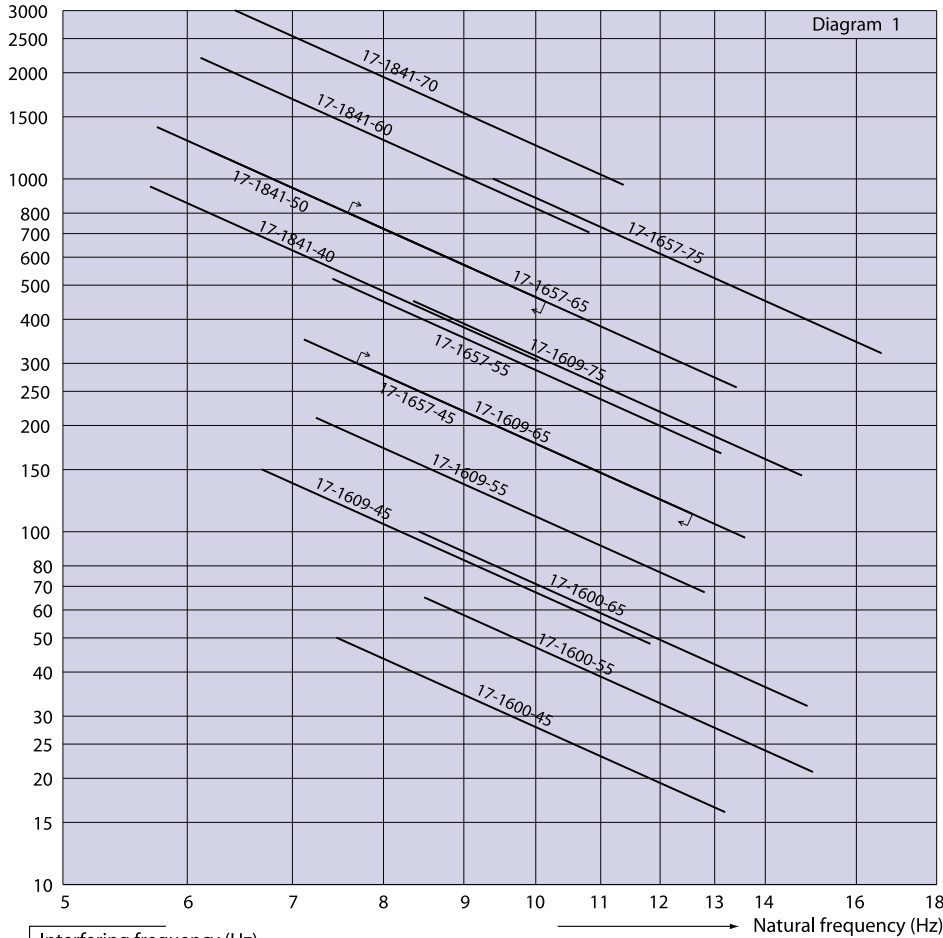

To select correct mounting, following data are needed:

- 1) Load per mounting (kg)
- 2) Interfering frequency (Hz)
(Hz = rpm / 60)

Select correct load line in diagram 1 and correct interference line in diagram 3. The load line intersects with required type of mounting.

Connect this intersection point vertically down to the interference line in diagram 3. Here, on the sloping curve, the isolation degree is indicated.

For static deflection, see diagram 2.

